

KF-JJY1'A
Spectrometer

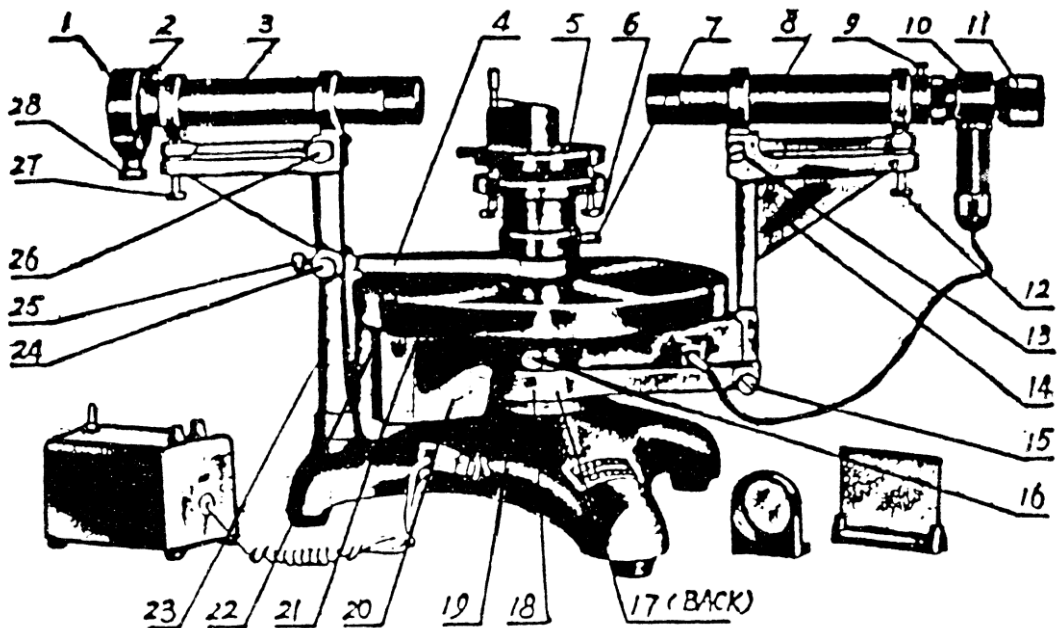

Fig 1

1.Slit Unit 2.Clamp Screw of Silt Unit 3.Collimator Unit 4.Brake Mount(No.2) 5.Stage 6.Level Screws of Stage(3pca) 7.Clamp Screw of Stage 8.Telescope Unit 9.Clamp Screw of Eyepiece 10.Abbe Self-collimating Eyepiece 11.Diopter Compensation Collar 12.Vertical Adjusting Screw of Telescopes Shaft 13.Level Screw of Telescope's Axis 14.Support 15.Fine Adjusting Knob of Telescope 16.Clamp Screw of Divided Circle 17.Stop Screw of Telescope 18.Brake Mount(No.1) 19.Chassis 20.Rotable Base 21.Divided Circle 22.Vernier Dial 23.Pillar 24.Adjustment Knob of Vernier 25.Stop Screw of Vernier 26.Horizontal Adjustment Screw for Collimator 27.Level Screw for Collimator 28.Slit Width Adjustment Drum

INSTRUCTIVE MANUAL

1. Specifications

- 1) Angle Measurement Accuracy 1'
- 2) Optical Parameter:
 - Focal Length 170mm
 - Effective Aperture Φ 30mm
 - Field of View $3^{\circ} 22'$
 - Focal Length of Telescope's Eyepiece 24.3mm
- 3) Max. Length Between Collimator and Telescope 120mm
- 4) Slit Width 0.02-2mm
- 5) Diopter Compensation Rang $\geq \pm 5$ diopters
- 6) Stage:
 - Diameter Φ 70mm
 - Rotating range 360°
 - Range of Vertical adjustment 20mm
- 7) Divided Circle:
 - Diameter Φ 178mm
 - Circle Graduation $0^{\circ} -360^{\circ}$
 - Division 0.5°
 - Vernier reading value 1'
- 8) Dimensions 251(W) \times 518(D) \times 250(H)
- 9) Net Weight 11.8kg
- 10) Attachments:
 - (1) Prism angle $60^{\circ} \pm 5'$
 - Material ZF1($n_D=1.6475$ $n_F-n_C=0.09192$)
 - (2) Transformer 6.3 V / 220 V (3 V A)
 - (3) Optical parallel plate
 - (4) Magnifier with handle
 - (5) Planar holographic grating 300/mm

2. Applications

The JJY Spectrometer is spectroscopic angle measurement instrument. It can be used for the angular measurements based on refraction, reflection, diffraction, interference or polarization.

For examples:

- 1) Measurement of prism angle Based on principle of reflection.
- 2) Min-deviation measurement of prism based on principle of refractive, computation of refractive index and dispersion of the material by which the prism is made.
- 3) Wave-length measurement and demonstration of the diffraction phenomenon in interference experiment when in conjunction with the grating.
- 4) Being used for the experiment of polarization using, zone plate and polarize.

3. General Description

The Spectrometer is showed in Fig.1.

Divided Circle 21 and Vernier Dial 22 is hold by the central spindle and is fixed to chassis 19, and they can be rotated around the spindle. There is a thrusting bearing under the divided circle that make the rotation smooth. The division of the divided circle is graduated in 30'. In order to eliminate errors induced by the offcenter errors of the divided circle, there are two verniers at the opposite edges. These Two readings should be averaged.

Pillar 23 is fixed to the chassis, and Collimator 3 is mounted on the pillar. The collimator's axis can be finely adjusted by the screws 26 and 27 on the pillar. Slit Unit 1 is outfit in the collimator, and can be move along or rotate around the axis, the width of the slit is changeable in the range 0.02-2mm.

Abbe Self-Collimating Telescope 8 is mount on Support 14 which is fixed to Rotable Base 20 and is mount on the circle. Loosing the clamp screw 16, the rotatable base and the divided circle will rotate independently, otherwise they will rotate as a whole. Using the clamp

Screw 17 on the brake(No.2) 18 telescope can be finely adjusted by the knob 15. Similarly, the axis of the telescope can be adjusted by the screws 12 and 13. Telescope's eyepiece can be moved along and rotated around the axis, its diopter can be adjusted also.

The field view of the reticule is shown as Fig.2.

The stage is mount on the vernier dial, it can rotated around the spindle. Loosing the screw 7 and 25, the stage will be finely adjusted by knob 24 of the pillar. The horizontal position of the stage can be Changed and fixed using screw 7. There are three level screws 6, by which the surface of the stage can be aligned to perpendicular to the axis of the spindle.

The power plug is connected to the socket of Chassis. For the convenience of the revolving of the telescope unit, the connection between the plug with the telescope unit, the connection between the plug with the socket of rotatable base is by means of a ring conductor

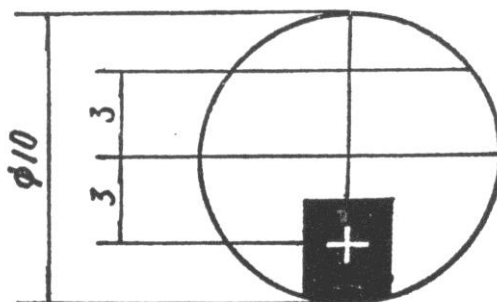

Fig 2

4.Setting

1) Focusing of eyepiece

To make the reticule is seem clear through the eyepiece, using collar 11, move the eyepiece backward at first, then move it forward until the image of the reticule is seem sharply. At last move it backward slowly to get the best image.

2) Focusing of telescope:

To put reticule's cross on the focal plane of telescope is equivalent to focus the telescope at infinity.

Method:

(1) Turn on the light. Insert the transformer's (6.3V) plug in the socket of Chassis, and insert the light's plug in rotatable's socket.

(2) Adjust the screws 12 and 13 to an adequate position.

(3) Put the optical parallel plate (attachment) on the stage, so that its reflecting faces to telescope objective, and is perpendicular to telescope axis.

(4) By adjusting screws 6 and rotating stage, make the reflected image of telescope and itself stand on the same line.

(5) Observing through the eyepiece, there is a bright patch. Move the eyepiece back and focus the telescope, make the image of bright cross sharp. By adjusting the stage, coincide this image with the cross hair which is on the upper of the reticule, without parallax.

3) Making telescope's axis perpendicular to the spindle:

(1) Adjust screw 12 and coincide the reflected cross image with cross hair itself accurately.

(2) Turn the vernier together with the parallel plate on the stage about 180 degrees, there would be a vertical displacement between the bright image of the cross and the cross hair itself, e.g. The cross may be a little too high or low.

(3) Adjust the stage's screws 3, to reduce the displacement to one half.

(4) Eliminate the vertical displacement, using telescope's level screw 12.

(5) Repeat the step from (2) to (4), until the deviation is eliminated completely.

4) Make the cross hair vertical and horizontal:

Turn the stage together with the parallel plate in respect to the telescope, and observe whether the bright cross moves horizontally or not. If the movement of the bright cross isn't parallel to the cross hair of the reticule, tilt the eyepiece to make it all right. Remember not to destroy the focusing of the telescope.

After this, using screw 9 clamp the eyepiece.

5) Focusing of the collimator:

The aim of this adjustment is to move the slit to the focal plane of the objective. It is equivalent to focus the collimator for infinity.

(1) Remove the illuminator from the eyepiece's mount, open the slit, and illuminate it with diffused light.

(2) Place a paper in front of collimator's objective. Observing the light spot on the paper, change the position of the light source so that the source illuminate the objective aperture uniformly.

(3) Take off the paper, adjust Screw(26) to a adequate position, make the telescope face to collimator. Observing through telescope's eyepiece, adjust knob 24 and level screw 27 of the collimator, make the image of the slit positioned in the centre of the view field.

(4) Move the slit unit back and forth. Until slit forms a sharp image on the reticule plane of the telescope.

(5) Make the collimator's axis perpendicular to the spindle:

Adjust Screw 27, make slit symmetrical about the centre of view field.

(6) Make slit perpendicular to the collimator:

Tilt the slit unit, make slit parallel to the vertical cross line of the reticule. Remember not to destroy the focusing of the collimator. Then clamp the slit by the clamp screw.

5. Maintenance

To make the instrument accurate, durable and without fault. Please service it carefully.

1) Don't use or store your instrument in the environment where the condition is dusty, moist and filling of corrosive gas.

2) When the instrument is not use for a long time, clear it and keep it in the instrument case with dryer.

3) Clear the dust of the optical parts with the brush, or clear it

carefully using cotton absorbed with alcohol or petrol. Take great care not to touch the optical surface by hand or things made by hard material.

4) Slit unit has been made and adjusted accurately. No further adjustment is necessary.

6. Packing List

1)KF- JJY-1' A Spectrometer	1
2) Prism	1
3) Optical Parallel Plate	1
4) Magnifier	1
5) Planar Holographic Grating	1
6) Transformer (6.3V/220,3VA)	1
7) Brush (include box)	1
8) Spare Lamp	
Small Lamp	3
Micro Lamp	3
9) Watch Screw Driver	1
Screw Driver size 2.5 inches	1
10) Dryer	1
11) Instructive Manual	1

7. Unpack and installation

Unpack the wood-box from the carton. Note, don't place upside down. Open the door of the box and remove three fixing screws and unpack the spectrometer.

The slit unit of Collimator and eyepiece unit of telescope (the illuminator is packed in the attached box), unpack them and install them in the tubes respectively. Because of the accurate fit between slit or eyepiece with their tubes, please clear them, then put them in tubes carefully, the slit should be put into the tube which is fixed on the pillar,

and the other should be put into the tube on the support.

8. APPENDIX

Example:

Measure the refractive index of prism's material using the method of minimum deviation.

1) Principle

As Fig.3 ABC is a prism with the surfaces AC and AB finely polished. The light incident upon the surface AB along P, and go out from AC along P'. The angle δ between P and P' is called deviation. If α is a constant, the deviation δ is changed with the different i_1 . If $i_1 = i_1'$, is minimum. We denote the minimum deviation angle by δ_{min} .

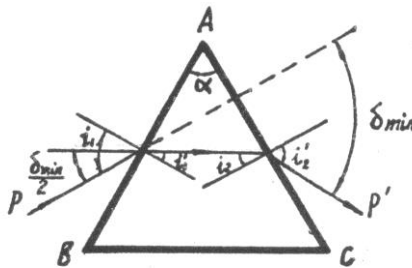

Fig.3

It is discovered from the Fig 3 that

$$i_1' = \alpha / 2, \quad \delta_{min} / 2 = i_1 - i_1' = i_1 - \alpha / 2;$$

$$i_1 = (\delta_{min} + \alpha) / 2$$

If the refractive index of prism's material is n . Then

$$\sin i_1 = n \sin i_1' = n \sin(\alpha / 2)$$

$$n = \sin i_1 / \sin(\alpha / 2) = \sin((\alpha + \delta_m) / 2) / \sin(\alpha / 2)$$

Hence we know, in order to set index n , we must measure:

(1) The vertex angle α of the prism.

(2) The minimum deviation δ_{\min} .

2) Adjusting before measurement

Refer to section 4.

3) Measurement of the vertex angle

(1) Take off the parallel plate and place the prism on the stage. Adjust the three level screws of stage to make the surfaces AC and AB perpendicular to the telescope's axis using the method of self-collimating.

(2) Alter the vernier's position to ensure that the vernier would not

be obscured by collimator or telescope. Tighten the brake (No.2) and vernier, and fix the screw of stage and vernier dial.

(3) Facing the telescope to the surface AB, tighten the clamp screws of the rotatable base and circle, brake (No.1) and chassis.

(4) Turn the adjusting screw at the end of the brake (No.1), Adjust the telescope gently and make the bright cross coincide with the cross hair completely.

(5) Write down the two vernier's readings at the opposite position and average these two readings value A_m .

(6) Loosening the stop screw of brake (No.1) and chassis, rotate the telescope make it facing the surface AC, fasten the stop screw of brake (No.1) and chassis.

(7) Repeat steps (4) and (5) and get the average B_m .

(8) Compute the vertex angle $\alpha = 180^\circ - (B_m - A_m)$.

Please do the above steps three times, and get the average value.

4) Measurement of the minimum deviation

(1) When the collimator's slit is illuminated by the monochrome light with required spectrum, the parallel light beam from collimator will be deflected because of the refraction of prism.

(2) Loosening the stop screws of brake (No.1) and chassis, rotate the telescope and find the slit's image of the collimator. Loosening stop screws of (No.2) and vernier dial, rotate the stage slowly. At first the slit's image observed through telescope move along one direction. When turn to the

position where the slit's image just begin to move along opposite direction. The prism's position of this where the light beam go out minimum deviation.

(3) Fasten the stop screws of brake (No.2) and vernier dial.

(4) By fine adjustment coincide the cross hair with the slit perfectly (at the middle part of the slit).

(5) Write down the two vernier's reading at the opposite edges, and get the average value C_m .

(6) Take of the prism the screws of brake (No.1) and chassis. Rotate the telescope, make it directly facing the collimator. Then tighten the stop screws of the brake (No.1) and chassis. Finely adjust the telescope, make the cross hair of reticule being aimed at the slit.

(7) Write down the two vernier's reading, and get average vale D_m .

(8) Compute the minimum deviation $\delta_m = D_m - C_m$.

Please do the above steps three times and get the average value.

5) Using the formula:

$$n = \frac{\sin(\alpha/2 + \delta_{\min}/2)}{\sin(\alpha/2)}$$

and get the refractive index.